

4X Leveling Pad Pin Dimension

- ① Electrical Connection
- ② Air Connection

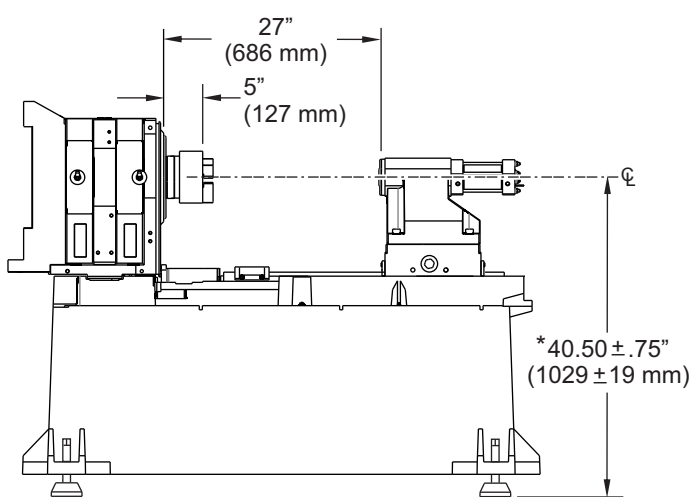

*Spindle center heights from floor, may vary due to leveling screw adjustments.

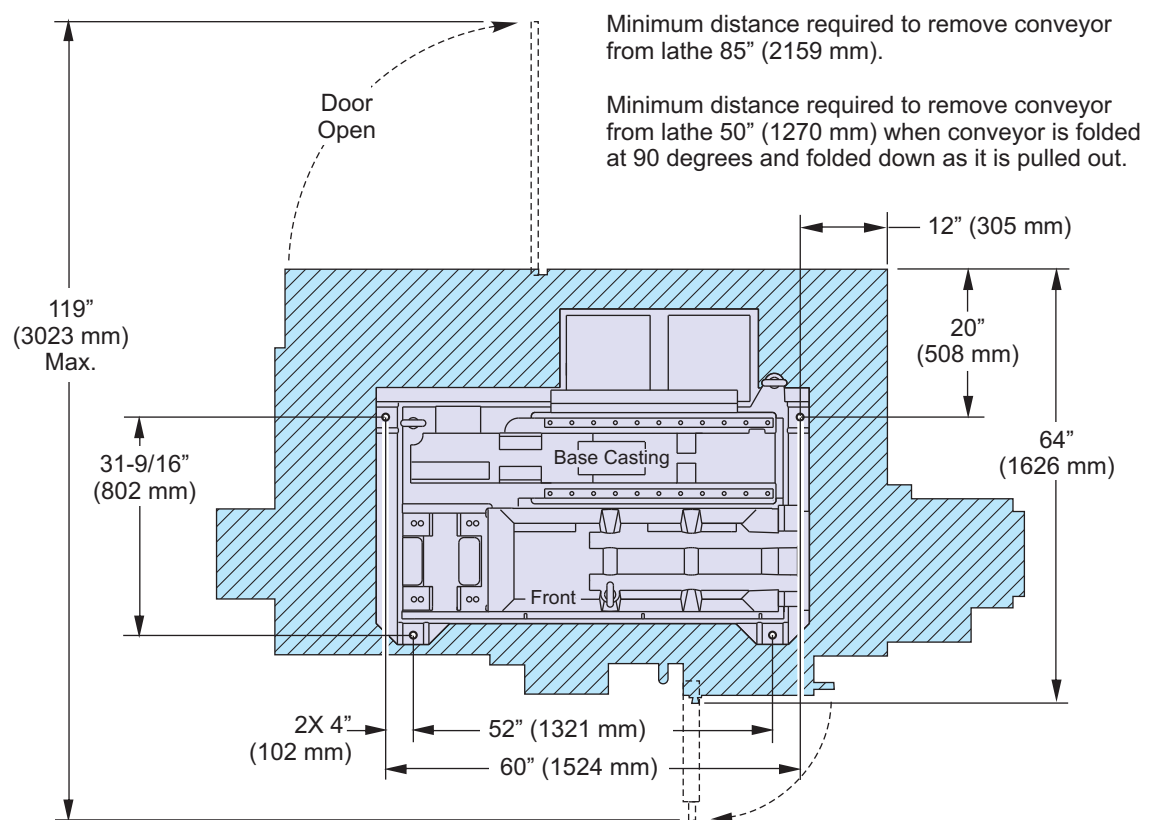
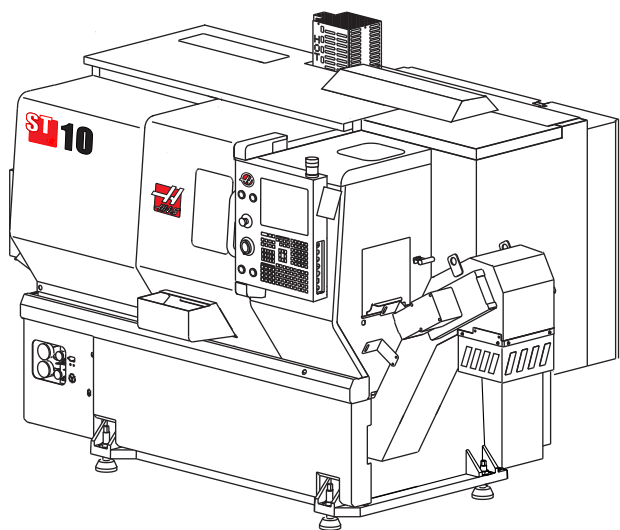
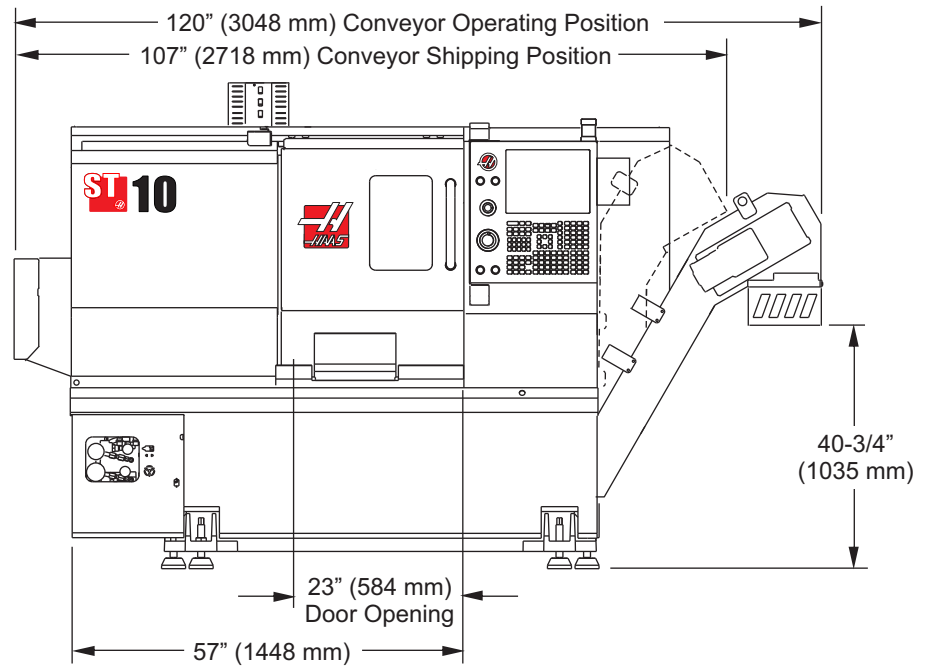
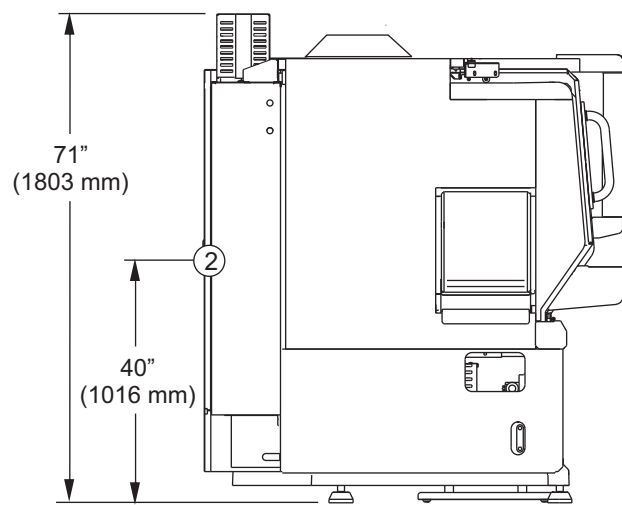
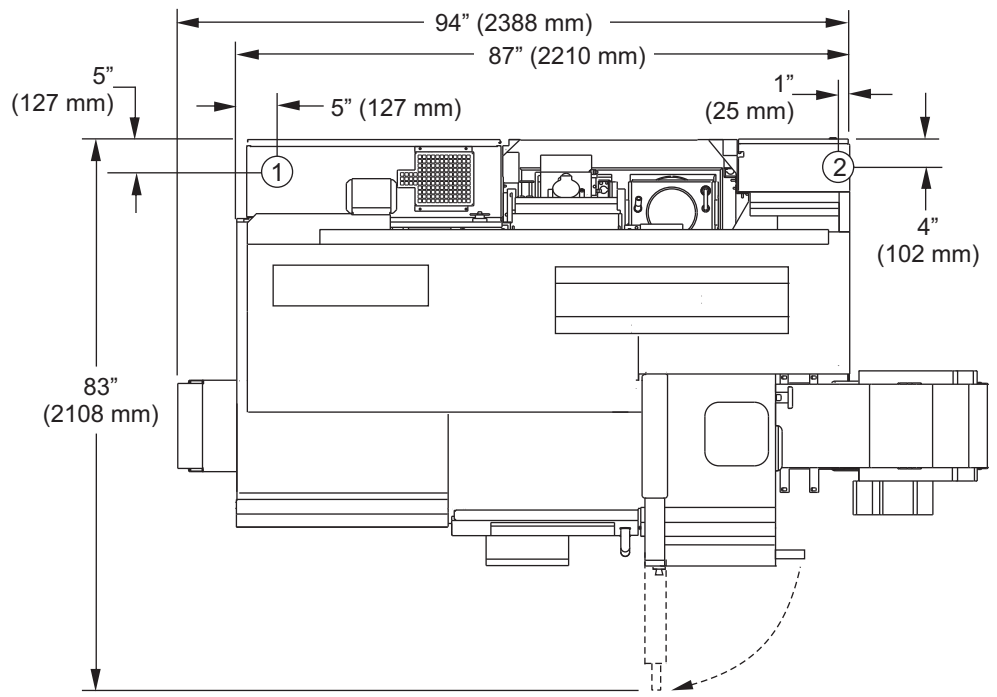
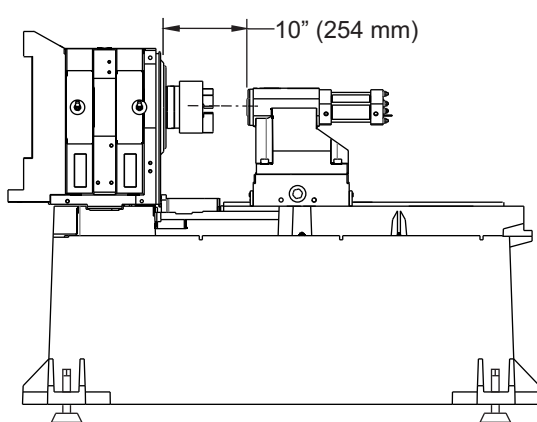

ST-10 Tailstock Travel
#3 Morse Taper

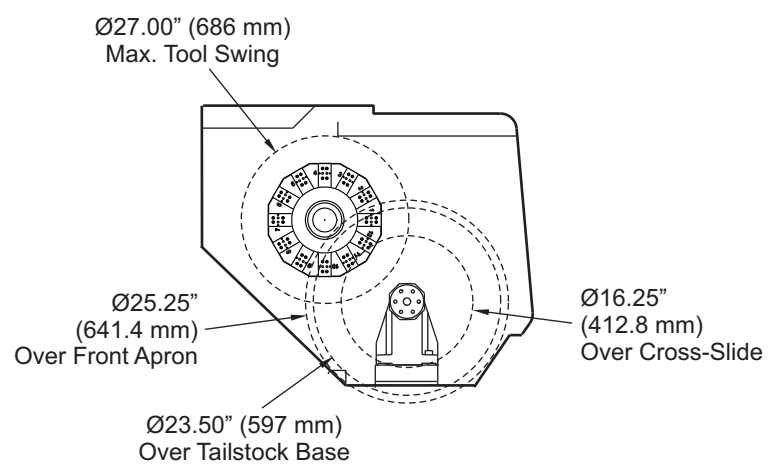

ST-10 Tool Swing Envelope
Turret at Home Position
12-Station BOT Turret Standard
VDI Turret Standard (HAE only)

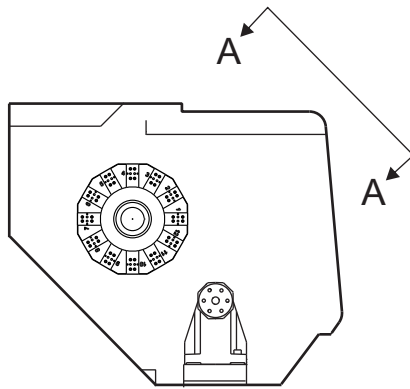

Assume short VDI holder on inner VDI pockets

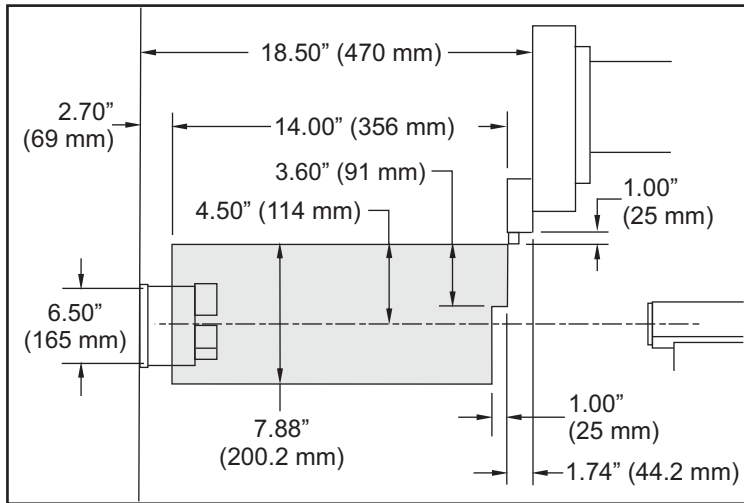

VDI OD TOOL
(Short Tool Holder)

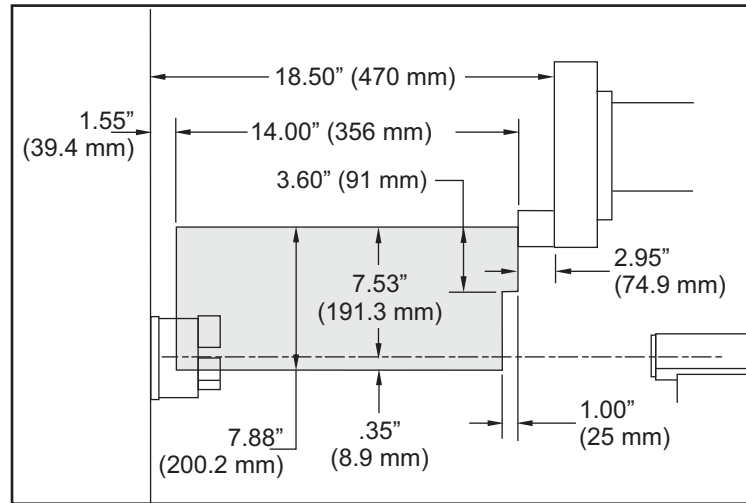

VDI ID TOOL

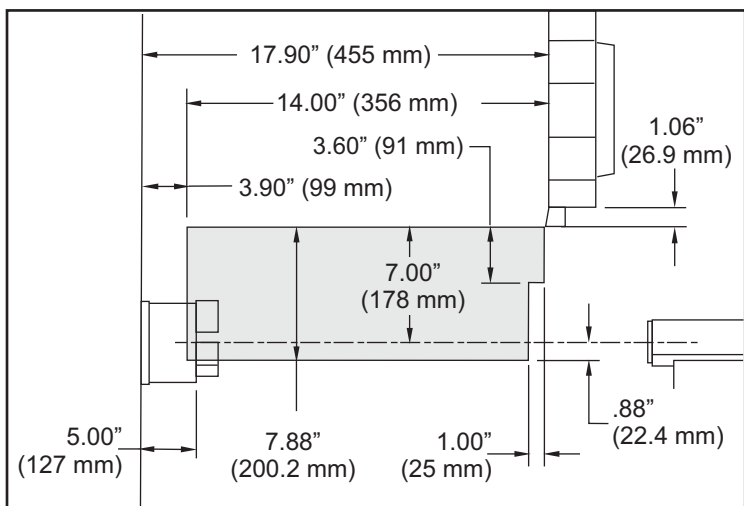

BOT OD TOOL

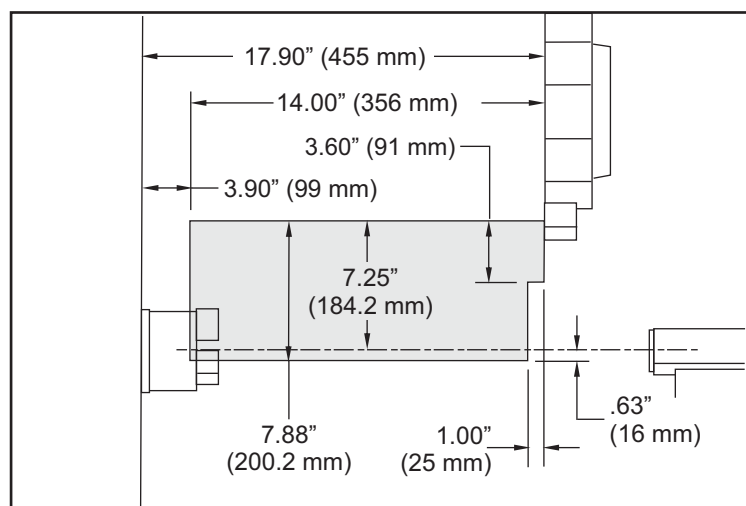

BOT ID TOOL

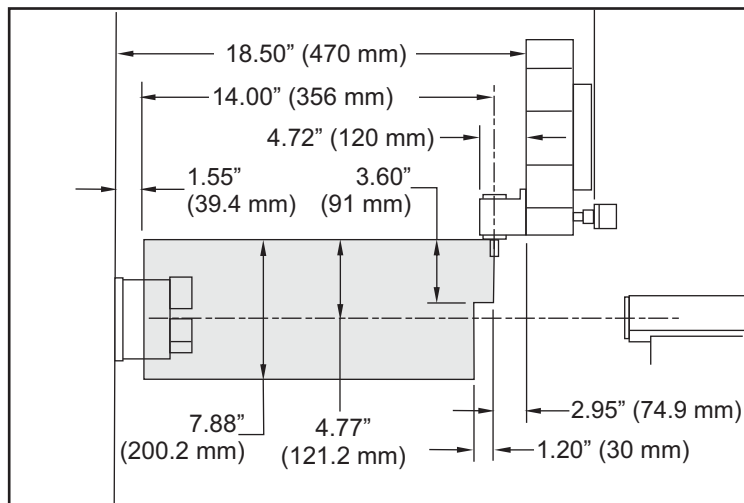

LIVE RADIAL TOOL

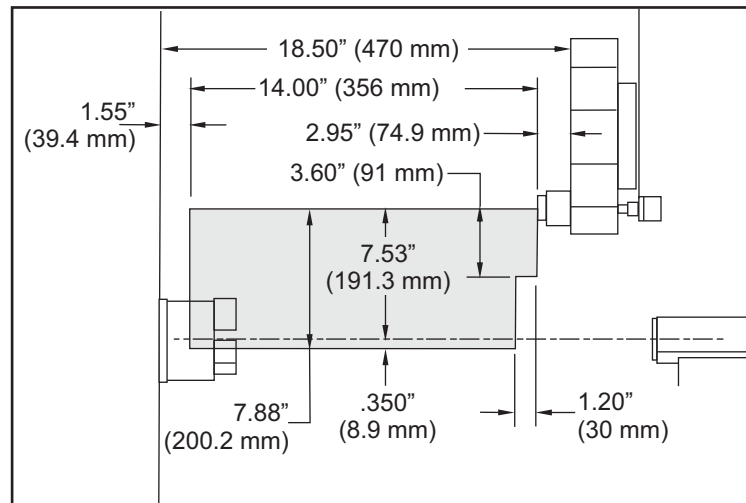

LIVE AXIAL TOOL

View A-A ST-10 Cut Envelope Diagrams

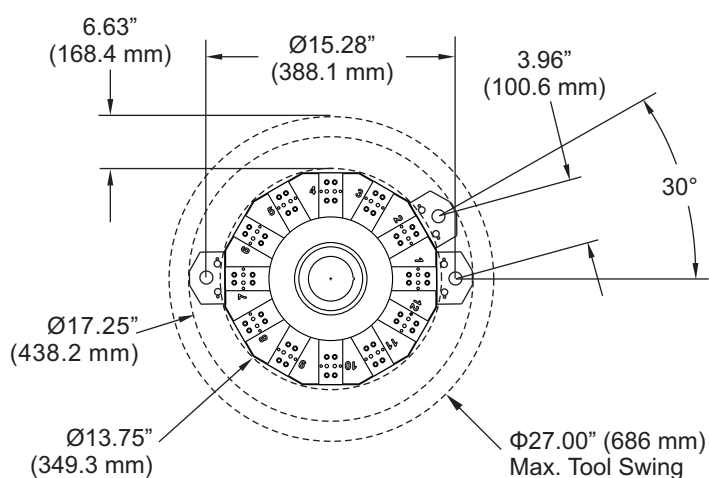

12-Station BOT Turret Standard

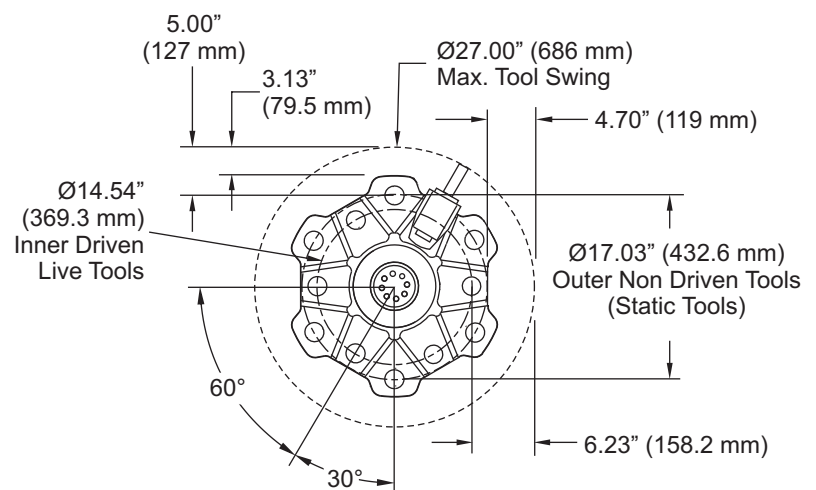

12-Station VDI Turret Option

ST-10 Tool Interference Drawings